

# Burners for gas ZIO, ZIOW

## OPERATING INSTRUCTIONS

Edition 09.22 · EN · 03250473

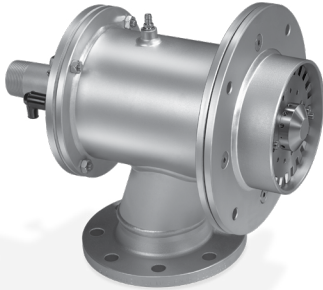

### CONTENTS

|  |    |
|--|----|
| 1 Safety . . . . .                                 | 1  |
| 2 Checking the usage . . . . .                     | 2  |
| 3 Installation . . . . .                           | 2  |
| 4 Wiring . . . . .                                 | 5  |
| 5 Preparing commissioning . . . . .                | 5  |
| 6 Commissioning . . . . .                          | 8  |
| 7 Maintenance . . . . .                            | 9  |
| 8 Assistance in the event of malfunction . . . . . | 11 |
| 9 Accessories . . . . .                            | 12 |
| 10 Technical data . . . . .                        | 12 |
| 11 Logistics . . . . .                             | 12 |
| 12 Disposal . . . . .                              | 12 |
| 13 Declaration of Incorporation . . . . .          | 13 |
| 14 Certification . . . . .                         | 13 |

## 1 SAFETY

### 1.1 Please read and keep in a safe place



Please read through these instructions carefully before installing or operating. Following the installation, pass the instructions on to the operator. This unit must be installed and commissioned in accordance with the regulations and standards in force. These instructions can also be found at [www.docuthek.com](http://www.docuthek.com).

### 1.2 Explanation of symbols

**1, 2, 3, a, b, c** = Action

→ = Instruction

### 1.3 Liability

We will not be held liable for damage resulting from non-observance of the instructions and non-compliant use.

### 1.4 Safety instructions

Information that is relevant for safety is indicated in the instructions as follows:

#### **⚠ DANGER**

Indicates potentially fatal situations.

#### **⚠ WARNING**

Indicates possible danger to life and limb.

#### **⚠ CAUTION**

Indicates possible material damage.

All interventions may only be carried out by qualified gas technicians. Electrical interventions may only be carried out by qualified electricians.

### 1.5 Conversion, spare parts



All technical changes are prohibited. Only use OEM spare parts.

## 2 CHECKING THE USAGE

Burner for heating industrial thermoprocessing equipment. For installation in a burner block or for use with an extended, heat-resistant burner tube. For natural gas, town gas and LPG. Other types of gas on request. This function is only guaranteed when used within the specified limits – see also page 12 (10 Technical data). Any other use is considered as non-compliant.

### 2.1 Type label

Construction stage, rated capacity  $Q_{max}$ , gas type – see type label.

|   |        |   |       |
|---|--------|---|-------|
|  |        |  |       |
| ZIO 165HB-100/35-(18)   |        |   |       |
| 84246114  |        | Ø   | mm    |
| P   | 630 kW |   | .3322 |

### 2.2 Type code

**ZIO** Burner for gas, with connection for ceramic tube

**ZIOW** Burner for gas, with ceramic fibre insulation (RCF)

**165-200** Burner size

**R** Cold air

**H** Hot air/high furnace temperature

**K** Flat flame

**B** Natural gas

**D** Coke oven gas, town gas

**G** Propane, propane/butane, butane

**M** Propane, propane/butane, butane (with mixer)

**L** Torch

**-X** X mm length of steel tube as of furnace flange (L1)

**/X** X mm distance from furnace flange to front edge of burner head (L2)

**-(X)** Burner head identifier

**-(XE)** Heat-resistant version

**A-Z** Construction stage

**H** High temperature version

## 2.3 Part designations

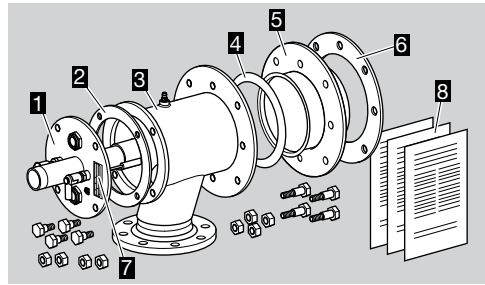

1 Burner insert

2 Gas housing gasket

3 Air housing

4 Burner tube gasket

5 Burner tube with mounting flange

6 Mounting gasket (not included in the delivery)

7 Type label

8 Operating instructions – for more documents and calculation tools, see [www.adlatus.org](http://www.adlatus.org)

### 2.4 Burner head

→ Check letter marking and identification marks on the burner head using the information provided on the type label.

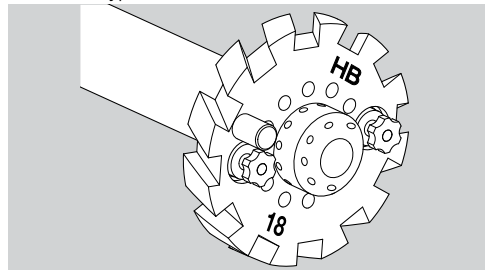

## 3 INSTALLATION

### 3.1 Conical burner block

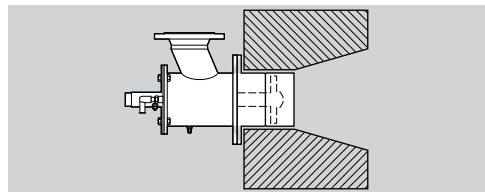

→ For industrial furnaces and kilns and for burning in an open combustion chamber.

→ Control: High/Low, continuous.

→ Type of burner head: R.

→ Max. capacity: 100%.

→ We recommend the cold air operating mode; otherwise the nitric oxide values will be too high.

### 3.2 Cylindrical burner block

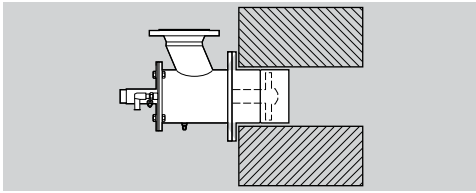

- For industrial furnaces and kilns and for burning in an open combustion chamber.
- Control: High/Low, High/Low/Off, continuous.
- Type of burner head: R, H.
- Max. capacity: 100%.
- Normal to medium flow velocity.

### 3.3 Tapered burner block

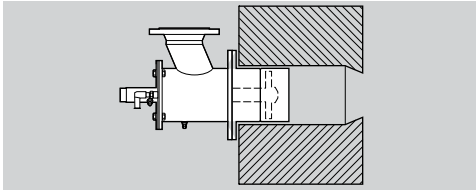

- For industrial furnaces and kilns and for burning in an open combustion chamber.
- Control: High/Low, High/Low/Off, continuous.
- Type of burner head: H.
- Max. capacity: approx. 80%, depending on the outlet diameter of the burner block.
- Medium to high flow velocity.

### 3.4 Flat flame burner block

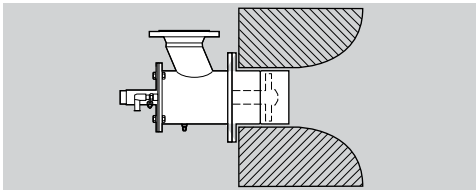

- For industrial furnaces and kilns and for burning in an open combustion chamber.
- Control: High/Low, High/Low/Off, continuous (limited turndown).
- Type of burner head: K.
- Capacity range: 40–100%.

### 3.5 Burners with attachment tube

- Position of the burner head near the interior furnace wall (  $L_2 = L_0 \pm 50$  mm).

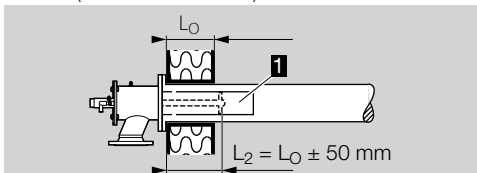

- Do not fit the attachment tube **1** directly in the furnace wall.
- Furnace temperature  $\leq 600^\circ\text{C}$ .

### 3.6 Radiant tube heating

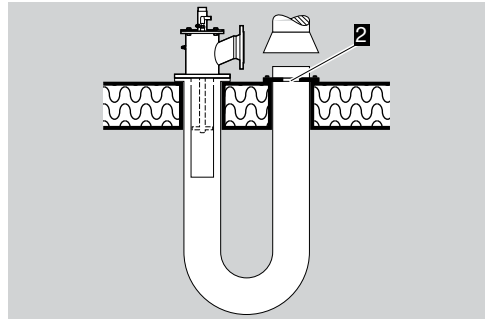

- Reduce the outlet diameter of the radiant tube using an orifice **2** to the point where a pressure loss of approx. 10 mbar occurs at the burner's rated capacity.

### 3.7 Hot air generation

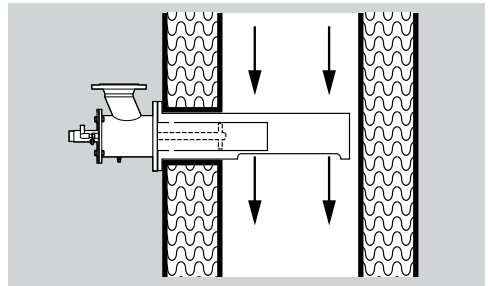
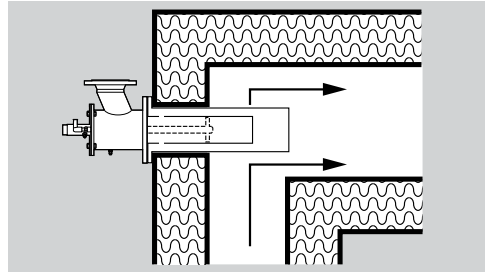

- At flow velocities of  $> 15$  m/s, the flame tube FPT is used to protect the flame from being cooled.

### 3.8 Installation on the furnace

- When installing, always ensure that when the burner is mounted, it is sealed tightly on the furnace wall.

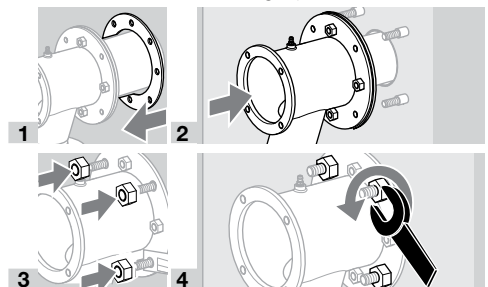

### 3.9 Air connection, gas connection

#### ZIO

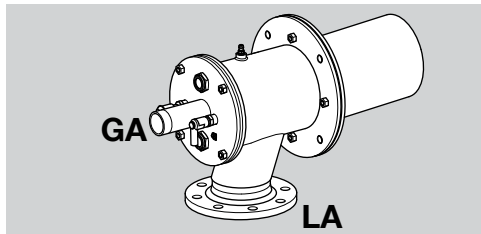

#### ZIOW

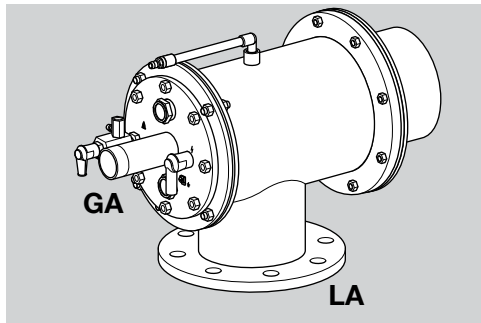

| Type     | Gas connection GA | Air connection LA |
|----------|-------------------|-------------------|
| ZIO 165  | Rp 1 1/2          | DN 100            |
| ZIO 200  | Rp 2              | DN 150            |
| ZIOW 165 | Rp 1 1/2          | DN 150            |
| ZIOW 200 | Rp 2              | DN 200            |

- Threaded connection to DIN 2999, flange dimensions to DIN 2633, PN 16.
- Install flexible tubes or bellows units to prevent mechanical stress or transmission of vibration.
- Ensure that the gaskets are undamaged.

#### **⚠ DANGER**

- Risk of explosion!
- Ensure the connection is air-tight.

#### 3.10 Connection to ANSI/NPT

- An adapter set is required for connection to ANSI/NPT, see page 12 (9.2 Adapter set).

| Type     | Gas connection GA | Air connection LA* |
|----------|-------------------|--------------------|
| ZIO 165  | 2–11.5 NPT        | 4.57"              |
| ZIO 200  | 2–11.5 NPT        | 6.72"              |
| ZIOW 165 | 1½ NPT–11,5 NPT   | 6.72"              |
| ZIOW 200 | 2 NPT–11,5 NPT    | 8.71"              |

Flange hole diameter.

- Weld flange **J** to air pipe **P** for air connection **LA** and use NPT thread adapter **H** for gas connection **GA**.

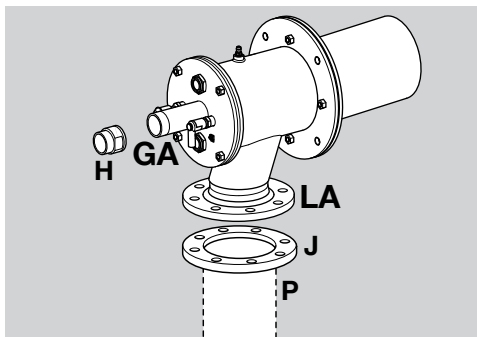

- The nozzle set with NPT thread is required for integrated pilots, see page 12 (9.3 Nozzle set).

#### 3.11 Pilot connections on the ZIO..L

- Air connection **la**.
- Gas connection **ga**.
- Pilot capacity: 1.5 kW.

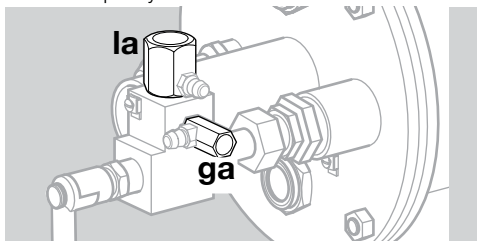

| Type                    | Pilot gas connection ga | Pilot air connection la |
|-------------------------|-------------------------|-------------------------|
| ZIO..L                  | Rp ¼                    | Rp ½                    |
| ZIO..L with adapter set | ¼" NPT                  | ½" NPT                  |

#### 3.12 Installing the burner insert

#### **⚠ WARNING**

- **ZIOW:** do not damage the surface of the insulation. Avoid the formation of dust.
- The burner insert can be rotated to the required position in increments of 90°.
- 1** Insert the gas housing gasket between the burner insert and the air housing.

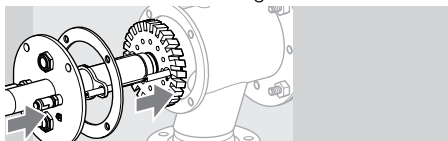

- 2** Tighten the burner insert in a crosswise fashion with max. 37 Nm (27.3 lbf ft):



## 4 WIRING

### **⚠ DANGER**

Electric shocks can be fatal!

- Before working on possible live components, ensure the unit is disconnected from the power supply.
- For the ignition and ionization cables, use (unscreened) high-voltage cable:  
FZLSi 1/6 up to 180°C (356°F), Order No. 04250410, or  
FZLK 1/7 up to 80°C (176°F), Order No. 04250409.

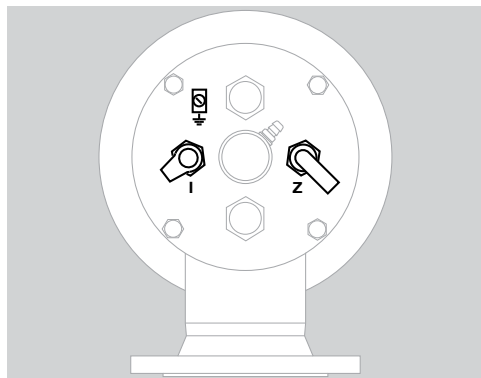

### **Flame rod I**

- Install the ionization cable well away from mains cables and interference from electromagnetic sources and avoid external electrical interference. Max. length of ionization cable – see automatic burner control unit operating instructions.
- Connect the flame rod to the automatic burner control unit via the ionization cable.

### **Spark electrode Z**

- Length of ignition cable: max. 5 m (15 ft), recommended < 1 m (40").
- For permanent ignition, max. ignition cable length 1 m (40").
- Lay the ignition cable individually and not in a metal conduit.
- Install the ignition cable separately from ionization and UV cables.
- A  $\geq 7.5$  kV,  $\geq 12$  mA ignition transformer is recommended; 5 kV for integrated pilot.

### **Flame rod and spark electrode**

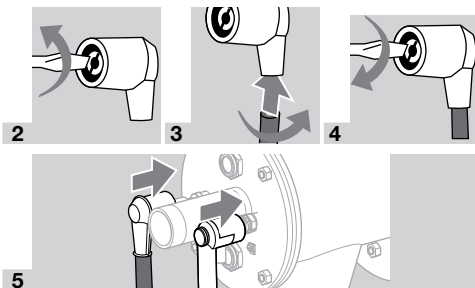
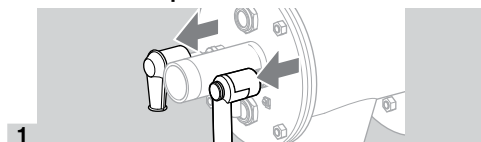

- 6 Connect the PE wire for burner ground to the burner insert. In the case of single-electrode operation, route the PE wire from the burner insert directly to the terminal on the automatic burner control unit.

### **⚠ WARNING**

High-voltage risk!

- It is essential that a high-voltage warning label be attached to the ignition cable.
- 7 For more detailed information on how to wire the ionization and ignition cables, refer to the operating instructions and connection diagrams of the automatic burner control unit and ignition transformer.

## 5 PREPARING COMMISSIONING

### **5.1 Safety instructions**

- Agree on settings and commissioning of the burner with the system operator or manufacturer.
- Check the entire system, upstream devices and electrical connections.
- Note the operating instructions for individual controls.

### **⚠ DANGER**

Risk of explosion!

- Please observe the appropriate precautions when igniting the burner.
- Pre-purge the furnace chamber or radiant tube with air (5 x volume) before every ignition attempt.
- Fill the gas line to the burner carefully and correctly with gas and vent it safely into the open air – do not discharge the test volume into the furnace chamber.

### **⚠ DANGER**

Risk of poisoning!

- Open the gas and air supply so that the burner is always operated with excess air – otherwise CO will form in the furnace chamber. CO is odourless and poisonous! Conduct a flue gas analysis.
  - The burner must only be commissioned by authorized trained personnel.
- If the burner does not ignite even though the automatic burner control unit has been switched on and off several times: check the entire system.

→ After ignition, monitor the flame and the gas and air pressure measured on the burner. Measure the ionization current. Switch-off threshold – see automatic burner control unit operating instructions.

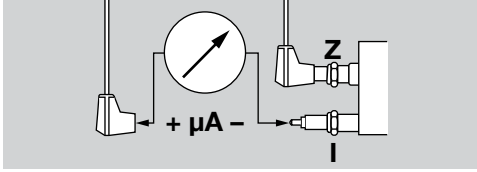

→ The burner must only be ignited at low-fire rate (between 10 and 30% of the rated capacity  $Q_{max}$ ) – see type label.

## 5.2 Determining the gas and combustion air flow rates

$$Q_{Gas} = P_B / H_i$$

$$Q_{Luft} = Q_{Gas} \cdot \lambda \cdot L_{min}$$

- $Q_{gas}$ : Gas flow rate in  $m^3/h$  ( $ft^3/h$ )
- $P_B$ : Burner capacity in kW (BTU/h)
- $H_i$ : Gas heating value in kWh/ $m^3$  (BTU/ $ft^3$ )
- $Q_{air}$ : Air flow rate in  $m^3(n)/h$  (SCFH)
- $\lambda$ : Lambda, air index
- $L_{min}$ : Minimum air requirement in  $m^3(n)/m^3(n)$  (SCF/SCF)
- Information on the gas quality supplied can be obtained from the gas supply company.

## Common gas qualities

| Gas type                | Heating value             |                      | $L_{min}$<br>$m^3(n)/m^3(n)$<br>(SCF/SCF) |
|-------------------------|---------------------------|----------------------|---|
|                         | $H_u$<br>kWh/<br>$m^3(n)$ | $H_o$<br>BTU/<br>SCF |   |
| Natural gas H           | 11.0                      | 1114                 | 10.6                                      |
| Natural gas L           | 8.9                       | 901                  | 8.6                                       |
| Propane                 | 25.9                      | 2568                 | 24.4                                      |
| Low calorific value gas | 1.7–3                     | 161–290              | 1.3–2.5                                   |
| Butane                  | 34.4                      | 3406                 | 32.3                                      |

- Data in kWh/ $m^3(n)$  refer to the lower heating value  $H_u$  and data in BTU/SCF refer to the higher heating value  $H_o$  (gross calorific value).
- A minimum air excess of 20% ( $\lambda = 1.2$ ) should be set in a cold furnace for initial adjustment since the air volume falls as the temperature rises.
- Fine adjustment should be carried out at max. furnace temperature and at as high a capacity demand as possible.

## 5.3 Notes on the flow rate curve

→ If the gas density in the operating state differs from that reflected in the flow rate curve, convert the pressures according to the local operating state.

$$P_B = P_M \cdot \frac{\delta_B}{\delta_M}$$

- $\delta_M$ : Gas density reflected in the flow rate curve in  $kg/m^3$  ( $lb/ft^3$ )
- $\delta_B$ : Gas density in operating state in  $kg/m^3$  ( $lb/ft^3$ )
- $p_M$ : Gas pressure reflected in the flow rate curve
- $p_B$ : Gas pressure in operating state
- 1 Read the gas pressure  $p_{gas}$  and air pressure  $p_{air}$  from the enclosed flow rate curve for cold air on the basis of the calculated flow rates  $Q$ .

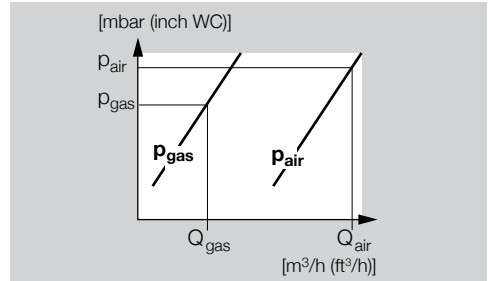

- Note possible capacity changes due to positive or negative pressures in the furnace/combustion chamber. Add positive pressures or subtract negative pressures.
- As not all the effects caused by the equipment are known, setting the burner using the pressure values is only approximate. It is possible to set the burner precisely by measuring the flow rates or flue gas.

## 5.4 Restrictors

→ The air volume required for the low-fire rate at a given air pressure is determined by the ignition position of a butterfly valve, a bypass hole in the air valve or an external bypass with restrictor.

## 5.5 Hot air compensation

→ The combustion air pressure  $p_{air}$  must be increased in hot air operating mode ( $\lambda = \text{constant}$ ).

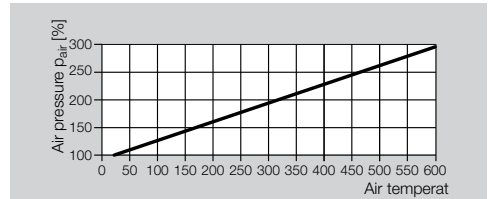

- The gas pressure is increased by 5–10 mbar.
- The total burner capacity  $P_{gas}$  rises as the air temperature increases.

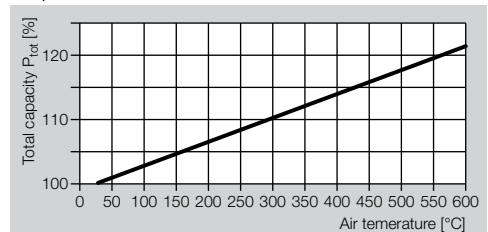

## 5.6 Burners with electrodes with air connection

→ Burner head marking (...D) or (...E)

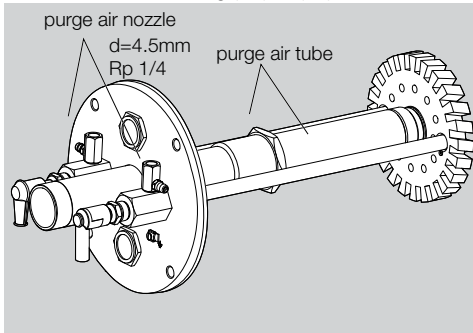

Pressures for purges electrodes

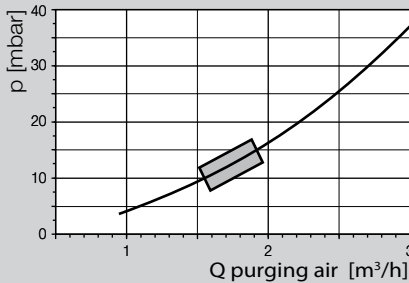

→ A purge air volume of approx. 1.5 to 2 m<sup>3</sup>/h per electrode is recommended.

→ The purge air may not be switched off until the furnace is cold and formation of condensation is no longer possible.

## 5.7 Setting the air pressure for low fire and high fire

1 Shut off the gas and air supply.

→ Air measuring nipple **L**, outside dia. = 9 mm (0.35").

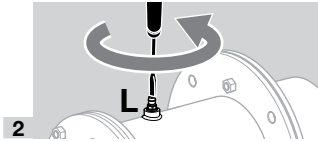

2 → Loosen the screw 2 turns.

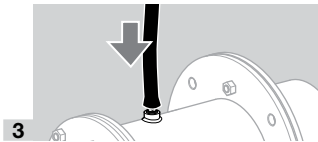

3 → Fully open the air supply.

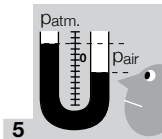

4 → Patm. = atmospheric pressure.

## Low-fire rate

→ The burner must only be ignited at low-fire rate (between 10 and 40% of the rated capacity  $Q_{\max}$  – see page 2 (2.1 Type label)).

6 Reduce the air supply on the air control valve and set the desired low-fire rate, e.g. using a limit switch or mechanical stop.

→ On air control valves with bypass, the bypass orifice should be determined on the basis of the required flow rate and the existing supply pressure if required.

## High-fire rate

7 Set the air control valve to high-fire rate.

8 Set the required air pressure  $p_{\text{air}}$  on the air restrictor upstream of the burner.

9 When using air restricting orifices: check the air pressure  $p_{\text{air}}$ .

## 5.8 Preparing the gas pressure measurement for low fire and high fire

1 Connect all measuring devices for subsequent fine adjustment of the burner.

→ Leave the gas supply closed.

→ Gas measuring nipple **G**, outside dia. = 9 mm (0.35").

1 Read the gas pressure  $p_{\text{gas}}$  for the required flow rate  $Q$  from the enclosed flow rate curve for cold air

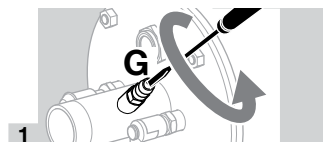
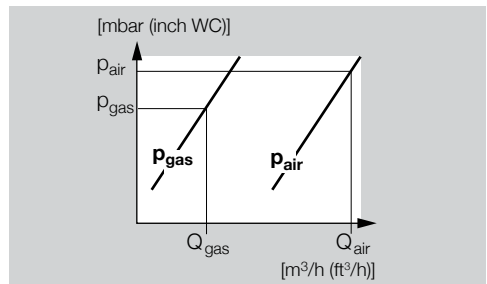

2 → Loosen the screw 2 turns.



## 5.9 Integrated pilot on the ZIO..L

→ Air pressure test nipple **I**, outside dia. = 9 mm (0.35").

→ Gas pressure test nipple **g**, outside dia. = 9 mm (0.35").

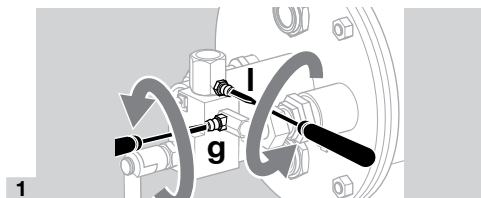

1  
→ Loosen the screws 2 turns.

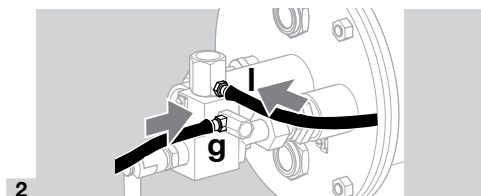

2  
→ Pilot:  
 $p_{\text{gas}} = 30\text{--}50 \text{ mbar}$ ,  
 $p_{\text{air}} = 30\text{--}50 \text{ mbar}$ .  
 → Check flame stability and ionization current.  
 → The gas and air pressure of the integrated pilot must be higher than the gas and air pressure of the main burner.

## 6 COMMISSIONING

### 6.1 Igniting and adjusting the burner

#### ⚠ WARNING

– Ensure adequate ventilation of the furnace chamber before each burner start!

→ The burner body will become hot during operation with preheated combustion air. Provide protection against accidental contact as required.

1 All valves of the installation must be checked for tightness before ignition.

#### 6.2 Setting the low-fire rate

1 Set the valves to ignition position.

2 Limit the maximum gas volume.

→ Should an adjustable gas restrictor be installed upstream of the burner, open the restrictor by approx. a quarter.

3 Open the gas supply.

4 Ignite the burner.

→ The safety time of the automatic burner control unit starts to elapse.

5 If no flame forms, check and adjust the gas and air pressures of the start gas adjustment.

6 In the case of operation with bypass (e.g. when using an air/gas ratio control): check the bypass nozzle and adjust if required.

7 In the case of operation without bypass (e.g. when using an air/gas ratio control without bypass): increase the low-fire rate setting.

8 Check the basic setting or bypass of the air control valve.

9 Check the position of the restrictor in the air line.

10 Check the fan.

11 Reset the automatic burner control unit and re-ignite the burner.

→ The burner ignites and proceeds to normal operation.

12 Check flame stability and ionization current at low-fire rate. Switch-off threshold – see automatic burner control unit operating instructions.

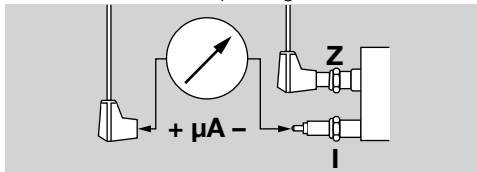

13 Monitor flame formation.

14 Adjust the low-fire rate settings if required.

15 If no flame is detected – see page 11 (8 Assistance in the event of malfunction).

#### 6.3 Setting the high-fire rate

1 Set the air and gas circuit of the burner to high fire while continuously monitoring the flame.

→ Avoid CO formation – always operate the burner with excess air when starting up!

→ When the desired maximum valve positions are reached, set the gas pressure  $p_{\text{gas}}$  using the restrictor upstream of the burner.

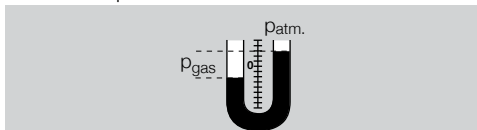

#### 6.4 Readjusting the air flow rate

1 Check the air pressure  $p_{\text{air}}$  on the burner and adjust using the air restrictor if required.

2 When using air restricting orifices: check the air pressure  $p_{\text{air}}$  and rework the orifice if required.

#### ⚠ DANGER

Risk of explosion and poisoning in case of burner adjustment with insufficient air!

– Adjust the gas and air supply so that the burner is always operated with excess air – otherwise CO will form in the furnace chamber. CO is odourless and poisonous! Conduct a flue gas analysis.

3 Measure the gas and air flow rates if possible. Determine the lambda value and readjust the settings if required.

#### 6.5 Tightness test

#### ⚠ DANGER

Escaping gas!

Danger from a leakage at the gas connections.

– Check the gas connections on the burner for leaks immediately after commissioning the burner.



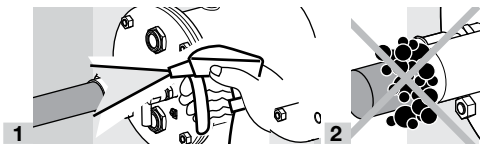

→ Avoid condensation due to the furnace atmosphere entering the burner body. While the burner is switched off, at furnace temperatures above 500°C (932°F), it must be cooled with a low air volume – see page 9 (6.6 Cooling air).

### 6.6 Cooling air

→ While the burner is switched off and depending on the furnace temperature, there must be a certain air flow for cooling the burner components.

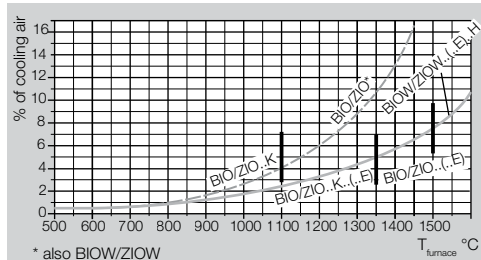

→ Diagram: the cooling air percentage specified in the diagram refers to the operating flow rate for air.

→ Leave the air fan switched on until the furnace has cooled down completely.

### 6.7 Blocking and recording the settings

- 1 Produce a measurement report.
- 2 Set the burner to low fire and check the settings.
- 3 Set the burner to low and high fire several times while monitoring the pressure settings, flue gas values and flame patterns.
- 4 Remove the measuring devices and close off the test nipples – tighten the grub screws.
- 5 Block and seal the adjusting elements.
- 6 Induce a flame failure, e.g. by pulling the terminal boot off the flame rod. The flame detector must close the gas safety valve and signal a fault.
- 7 Switch the system on and off several times while monitoring the automatic burner control unit.
- 8 Produce an acceptance report.

### **⚠ DANGER**

Risk of explosion in case of CO being formed in the furnace chamber! CO is odourless and poisonous!

An incorrect change of the burner settings may change the gas/air ratio and lead to unsafe operating conditions:

- All interventions may only be carried out by qualified gas technicians.

## 7 MAINTENANCE

→ Maintenance and function check every six months. If the media are highly contaminated, this interval should be reduced.

### **⚠ DANGER**

Risk of explosion!

- Please observe the appropriate precautions when igniting the burner.
- Maintenance work on the burner must be carried out by authorized trained personnel only.

### **⚠ DANGER**

Risk of burning!

- Outflowing flue gases and burner components are hot.

→ We recommend that all the gaskets removed during maintenance work be replaced. The appropriate gasket set is available separately as a spare part.

1 Check the ionization and ignition cables.

2 Measure the ionization current.

→ The ionization current must be at least 5 µA and must not vary.

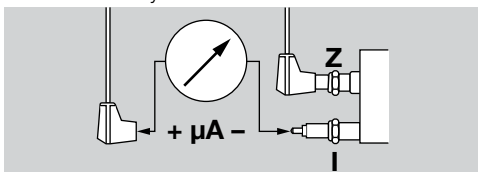

3 Disconnect the system from the electrical power supply.

4 Shut off the gas and air supply – do not change the restrictor settings.

### 7.1 Checking the spark electrode and flame rod

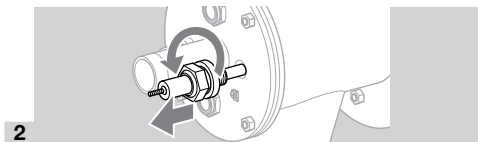
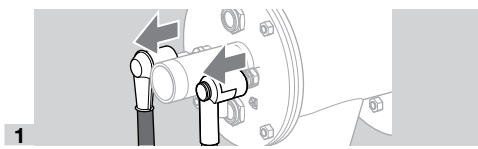

→ Ensure that the electrode length does not change.

3 Remove dirt from electrodes or insulators.

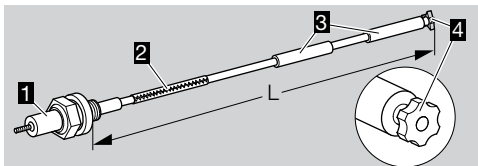

4 If the star 4 or insulator 3 is damaged, replace the electrode.

→ Before changing the electrode, measure the total length **L**.

**5** Connect the new electrode with the spark plug **1** using the dowel pin **2**.

**6** Adjust spark plug and electrode to the measured total length **L**.

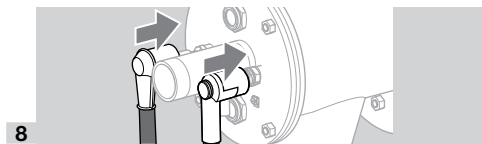
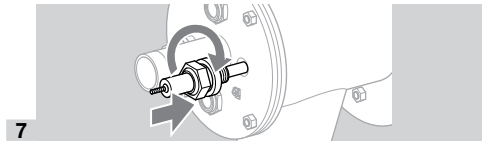

→ Turning the spark plug makes it easier to feed the electrode into the burner insert.

## 7.2 Checking the burner

### Removing and installing burner insert ZIOW

→ Do not damage the surface of the insulation.

→ Avoid the formation of dust.

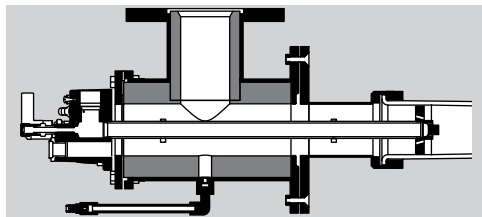

### ZIO and ZIOW

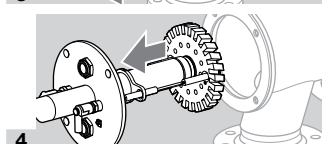
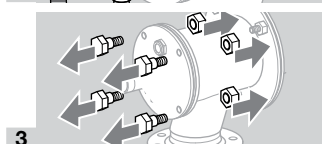

→ If the burner insert is dismantled, the gas housing gasket will have to be renewed.

**5** Place the burner insert in a safe place.

→ Depending on the amount of dirt or wear: replace the spark electrode/flame rod and dowel pin during servicing – see page 9 (7.1 Checking the spark electrode and flame rod).

**6** Check burner head for dirt and thermal cracks.

## ⚠ WARNING

Risk of injury!

– Burner heads have sharp edges.

→ When replacing any burner components: apply ceramic paste to the screw connections in order to avoid cold-setting – see page 12 (9.1 Ceramic paste).

**7** Check the electrode positions.

→ The insulator must be flush with the front edge of the burner air disc.

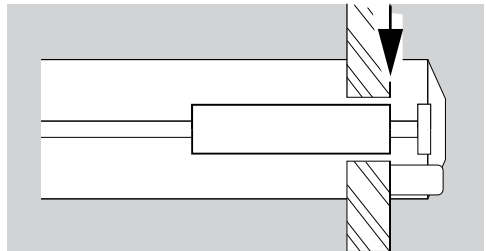

→ Distance of spark electrode from ground pin or gas nozzle:  $2 \pm 0.5 \text{ mm}$  ( $0.08 \pm 0.02 \text{ inch}$ ).

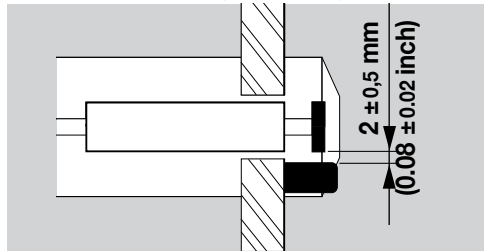

**8** When the furnace chamber has cooled down, check the burner tube and burner block through the furnace flange.

→ Replace the gas housing gasket.

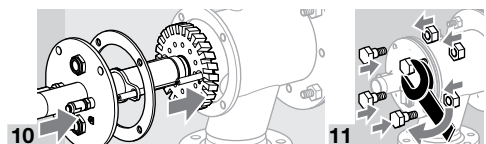
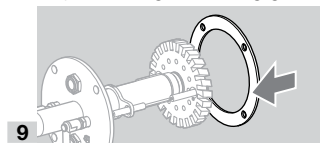

→ Tighten the burner insert with max. 37 Nm (27.3 lb ft).

**12** Connect the system to the electrical power supply.

**13** Open the gas and air supply.



- 16** Set the burner to low fire and compare the pressure settings to those stated in the acceptance report.
- 17** Set the burner to low and high fire several times while monitoring the pressure settings, flue gas values and flame patterns.

### **DANGER**

Risk of poisoning!

- Open the gas and air supply so that the burner is always operated with excess air – otherwise CO will form in the combustion chamber. CO is odourless and poisonous! A flue gas analysis should be conducted.

### **DANGER**

Risk of explosion and poisoning in case of burner adjustment with insufficient air!

- Adjust the gas and air supply so that the burner is always operated with excess air – otherwise CO will form in the furnace chamber. CO is odourless and poisonous! Conduct a flue gas analysis.

- 18** Produce a maintenance report.

## **8 ASSISTANCE IN THE EVENT OF MALFUNCTION**

### **DANGER**

Electric shocks can be fatal!

- Before working on possible live components, ensure the unit is disconnected from the power supply.

### **DANGER**

Risk of injury!

Burner heads have sharp edges.

- Burner inspection must only be performed by authorized trained personnel.

- If no issues are found when checking the burner, proceed to the automatic burner control unit and check for faults in accordance with the relevant operating instructions.

#### **? Fault**

- !** Cause
- Remedy

#### **? Burner does not function.**

- !** Valves do not open.
- Check the voltage supply and wiring.

- !** Tightness control signals a fault.
- Check the valves for tightness.
  - Note the tightness control operating instructions.

- !** Control valves do not move to low-fire rate position.
- Check the impulse lines.

- !** Gas inlet pressure is too low.
- Check the filter for dirt.

- Check the gas supply.

- !** Air inlet pressure is too low.
- Check the fan and air supply.
- !** Gas and air pressures on the burner are too low.
- Check the restrictors.
  - Check/adjust the start rate setting, see operating instructions for solenoid valve.
- !** Automatic burner control unit does not function correctly.
- Check the device fuse.
  - Note the automatic burner control unit operating instructions.
- !** Automatic burner control unit signals a fault.
- Check the ionization cable.
  - Check the ionization current. The ionization current must be at least 5  $\mu\text{A}$  – stable signal.
  - Check whether the burner is adequately grounded.
  - Note the automatic burner control unit operating instructions.
- !** No ignition spark is created.
- Check the ignition cable.
  - Check the voltage supply and wiring.
  - Check whether the burner is adequately grounded.
  - Check the electrode – see page 9 (7 Maintenance).
- !** Defective insulator on the electrode, ignition spark jumps over incorrectly.
- Check the electrode.
- ? Burner performs a fault lock-out after operating faultlessly in normal operation.**
- !** Incorrect gas and air flow rate settings.
- Check the differential pressures for gas and air.
- !** Automatic burner control unit signals a fault.
- Check the ionization cable.
  - Check the ionization current. The ionization current must be at least 5  $\mu\text{A}$  – stable signal.
- !** Burner head is dirty.
- Clean gas and air bore holes and air slots.
  - Remove deposits.
- !** Excessive pressure fluctuations in the combustion chamber.
- Ask Honeywell Kromschroder for control concepts.

## 9 ACCESSORIES

### 9.1 Ceramic paste

For avoiding cold-setting on screw connections after replacing burner components. Order No.: 050120009.

### 9.2 Adapter set

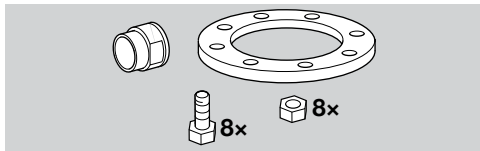

For connecting ZIC to NPT/ANSI connections.

| Burner  | Adapter set | Order No. |
|---------|-------------|-----------|
| ZIO 165 | BR 165 NPT  | 74922636  |
| ZIO 200 | BR 200 NPT  | 74922637  |

Adapted set for ZIOW on request.

### 9.3 Nozzle set

→ Available on request for connecting integrated pilots to NPT threads.

## 10 TECHNICAL DATA

Gas supply pressure and air supply pressure each depend on the use and gas type.

#### Gas and air pressures:

see burner diagrams at [www.docuthek.com](http://www.docuthek.com). Special gaskets are available on request for air pressures of > 100 mbar (39.4 "WC) (e.g. reverse flow pressure in the furnace).

#### Burner flow rate curves:

A web app to view the burner flow rate curves is available at [www.adlatus.org](http://www.adlatus.org).

#### Gas types:

natural gas, LPG (gaseous), coke oven gas, town gas and low calorific value gas; other gases on request.

#### Combustion air:

The air must be dry and clean in all temperature conditions and must not contain condensate.

#### Overall lengths:

100 to 500 mm (3.9 to 19.7 inches) or 50 to 450 mm (2 to 17.7 inches), length increments: 100 mm (3.94 inches) (other lengths available on request).

#### Control type:

staged: On/Off, modulating: constant  $\lambda$  value.

#### Flame control:

with flame rod (UV control as an option).

#### Ignition:

direct spark ignition; integrated pilot as an option. Storage temperature: -20°C to +40°C.

#### Burner body:

ZIO: St,  
ZIOW: St + internal insulation.

Most of the burner components are made of corrosion-resistant stainless steel.

#### Ambient conditions:

-20°C to +180°C (68°F to 356°F) (outside the thermoprocessing system); no condensation permitted, painted surfaces may corrode.

#### Maximum furnace temperature:

ZIO(W) in burner block:  
up to 1600°C (up to 2912°F),  
ZIO with burner attachment tube:  
up to 600°C (up to 1112°F).

#### Maximum air temperature:

ZIO: up to 450°C (842°F),  
ZIOW: up to 600°C (1112°F).

### 10.1 REACH Regulation

applies to ZIOW only. Information pursuant to REACH Regulation No. 1907/2006, Article 33.

Insulation contains refractory ceramic fibres (RCF)/aluminium silicate wool (ASW).

RCF/ASW are listed in the Candidate List of the European REACH Regulation No. 1907/2006.

## 11 LOGISTICS

### Transport

Protect the unit from external forces (blows, shocks, vibration).

Transport temperature: see page 12 (10 Technical data).

Transport is subject to the ambient conditions described.

Report any transport damage on the unit or packaging without delay.

Check that the delivery is complete.

### Storage

Storage temperature: see page 12 (10 Technical data).

Storage is subject to the ambient conditions described. Storage time: 6 months in the original packaging before using for the first time. If stored for longer than this, the overall service life will be reduced by the corresponding amount of extra storage time.

## 12 DISPOSAL

Devices with electronic components:

### WEEE Directive 2012/19/EU – Waste Electrical and Electronic Equipment Directive



At the end of the product life (number of operating cycles reached), dispose of the packaging and product in a corresponding recycling centre. Do not dispose of the unit with the usual domestic refuse. Do not burn the product. On request, old units may be returned carriage paid to the manufacturer in accordance with the relevant waste legislation requirements.

# 13 DECLARATION OF INCORPORATION

Honeywell

according to 2006/42/EC, Annex II, No. 1B  
The product ZIO/ZIOW is a partly completed machine pursuant to Article 2g and is designed exclusively for installation in or assembly with another machine or other equipment.

The following essential health and safety requirements in accordance with Annex I of this Directive are applicable and have been fulfilled:  
Annex I, Articles 1.1.3, 1.1.5, 1.3.2, 1.3.4., 1.5.2, 1.7.4, 1.5.10.

The relevant technical documentation has been compiled in accordance with part B of Annex VII and will be sent to the relevant national authorities on request as a digital file.

The following (harmonized) standards have been applied:

- EN 746-2:2010 – Industrial thermoprocessing equipment; Safety requirements for combustion and fuel handling systems
- EN ISO 12100:2010 – Safety of machinery – General principles for design – Risk assessment and risk reduction (ISO 12100:2010)

The following EU Directives are fulfilled:  
RoHS II (2011/65/EU)

The partly completed machine may only be commissioned once it has been established that the machine into which the product mentioned above is to be incorporated complies with the provisions of the Machinery Directive 2006/42/EC.  
Elster GmbH

**Einbauerklärung**  
nach 2006/42/EG, Anhang II, Nr. 1B

**/ Declaration of Incorporation**  
/ according to 2006/42/EC, Annex II No. 1B

Folgendes Produkt / The following product:

Bezeichnung:  
Description  
Typenbezeichnung / Type:  
Markenname / Branding:

Brenner für Gas  
Burner for gas  
B10, B10A, Z10, B1C, B1CA, Z1C  
B10W, Z10W, B1CW, Z1CW

**kromschroder**

ist eine unvollständige Maschine nach Artikel 2g und ausschließlich zum Einbau in oder zum Zusammenbau mit einer anderen Maschine oder Ausrüstung vorgesehen.  
Is a partly completed machine pursuant to Article 2g and is designed exclusively for installation in or assembly with another machine or other equipment.

Folgende grundlegende Sicherheits- und Gesundheitschutzanforderungen gemäß Anhang I dieser Richtlinie kommen zur Anwendung und wurden eingehalten:  
The following essential health and safety requirements in accordance with Annex I of this Directive are applicable and have been fulfilled:

Anhang I, Artikel / Annex I, Article  
1.1.3, 1.1.5, 1.3.2, 1.3.4, 1.5.2, 1.7.4, 1.5.10

Die speziellen technischen Unterlagen gemäß Anhang VII B wurden erstellt und werden der zuständigen nationalen Behörde auf Verlangen in elektronischer Form übermittelt.  
The relevant technical documentation has been compiled in accordance with part B of Annex VII and will be sent to the relevant national authorities on request as a digital file.

Folgende (harmonisierte) Normen wurden angewandt: / The following (harmonized) standards have been applied:  
EN 746-2:2010 – Industrielle Thermoprocessing-Equipments; Sicherheitsanforderungen an Feueranlagen und Brennstoffeintragungssysteme – Industrial thermoprocessing equipment; Safety requirements for combustion and fuel handling systems  
EN ISO 12100:2010 – Sicherheit von Maschinen – Allgemeine Gestaltungsgrundsätze – Risikobeurteilung und Risikoreduzierung (ISO 12100:2010)  
– Safety of machinery – General principles for design – Risk assessment and risk reduction (ISO 12100:2010)

Folgende EU-Richtlinien werden erfüllt: / The following EU directives are fulfilled:  
RoHS II (2011/65/EU)

Die unvollständige Maschine darf erst dann in Betrieb genommen werden, wenn festgelegt wurde, dass die Maschine, in der das oben bezeichnete Produkt eingebaut werden soll, den Bestimmungen der Richtlinie für Maschinen (2006/42/EG) entspricht.  
The partly completed machine may only be commissioned once it has been established that the machine into which the product mentioned above is to be incorporated complies with the provisions of the Machinery Directive 2006/42/EC.

Lotte (Bauern)

10.07.2019  
Datum / Date

*M. Rieken S. Escher*

**M. Rieken, S. Escher**  
Konstrukteur / Designer

M. Rieken, S. Escher sind bevollmächtigt, die speziellen technischen Unterlagen gemäß Anhang VII B zusammenzustellen.  
M. Rieken, S. Escher are authorized to compile the relevant technical documentation according to Annex VII B.

Elster GmbH

Postfach 20 09  
34109 Löhndorf  
34109 Löhndorf  
Tel. +49 (0)511 12 142  
Fax. +49 (0)511 12 142 70  
info@kromschroder.com  
www.kromschroder.com

# 14 CERTIFICATION

## 14.1 Eurasian Customs Union



The products ZIO meet the technical specifications of the Eurasian Customs Union.

## 14.2 China RoHS

Directive on the restriction of the use of hazardous substances (RoHS) in China. Scan of the Disclosure Table China RoHS2, see certificates at [www.docuthek.com](http://www.docuthek.com).

## FOR MORE INFORMATION

The Honeywell Thermal Solutions family of products includes Honeywell Combustion Safety, Eclipse, Exothermics, Hauck, Kromschroder and Maxon. To learn more about our products, visit [ThermalSolutions.honeywell.com](http://ThermalSolutions.honeywell.com) or contact your Honeywell Sales Engineer.

Elster GmbH  
Strotheweg 1, D-49504 Lotte  
T +49 541 1214-0  
[hts.lotte@honeywell.com](mailto:hts.lotte@honeywell.com)  
[www.kromschroeder.com](http://www.kromschroeder.com)

Global centralized service deployment coordination:  
T +49 541 1214-365 or -555  
[hts.service.germany@honeywell.com](mailto:hts.service.germany@honeywell.com)

Translation from the German  
© 2022 Elster GmbH

